

# SPECIFICATION

REDUNDANT POWER SUPPLY

HOT-SWAPPABLE

BPS-900RP3 6-OUTPUT

WITH ACTIVE PFC FUNCTION

900W+450W

BEST POWER SOLUTIONS, INC.

2F, NO.196-10, SEC.3, DA-TONG RD., XIZHI  
DIST., NEW TAIPEI CITY, TAIWAN R.O.C.

Tel: 886-2-8647-1188

Fax: 886-2-8647-3322

<b>1.0</b>	<b>General</b>
<b>1.1</b>	<b>Parameter Specifications</b>
<b>2.0</b>	<b>Input Characteristics</b>
<b>2.1</b>	<b>Input Voltage</b>
<b>2.2</b>	<b>Input Waveform</b>
<b>2.3</b>	<b>Input Frequency</b>
<b>2.4</b>	<b>Input Current</b>
<b>2.5</b>	<b>In-Rush Current</b>
<b>2.6</b>	<b>Line Regulation</b>
<b>2.7</b>	<b>Input Leakage Current</b>
<b>2.8</b>	<b>Isolation (Hi-Pot)</b>
<b>3.0</b>	<b>Output Characteristics</b>
<b>3.1</b>	<b>DC Output Characteristics</b>
<b>3.2</b>	<b>Overshoot</b>
<b>3.3</b>	<b>Efficiency</b>
<b>4.0</b>	<b>Time Sequence</b>
<b>4.1</b>	<b>Hold-Up Time</b>
<b>4.2</b>	<b>Power Good Signal</b>
<b>4.3</b>	<b>+5 Volt &amp; +3.3V Power Good Output Rise Time</b>
<b>4.4</b>	<b>Start-Up Time</b>
<b>4.5</b>	<b>Dynamic Load Response Time</b>
<b>5.0</b>	<b>Protection</b>
<b>5.1</b>	<b>Over Power Protection</b>
<b>5.2</b>	<b>Over Voltage Protection</b>
<b>5.3</b>	<b>Short Circuit Protection</b>
<b>5.4</b>	<b>No Load Operation</b>
<b>5.5</b>	<b>5VSB (Standby)</b>
<b>5.6</b>	<b>PS-ON (Remote ON/OFF)</b>
<b>5.7</b>	<b>3.3V Sense</b>
<b>6.0</b>	<b>System Interface Signal</b>
<b>6.1</b>	<b>Power System Fault Signal</b>
<b>6.2</b>	<b>Alarm Beeping Sound</b>

<b>7.0</b>	<b>Physical Characteristics</b>
<b>7.1</b>	<b>Size</b>
<b>7.2</b>	<b>Mounting Requirements</b>
<b>7.3</b>	<b>Weight</b>
<b>7.4</b>	<b>Cooling</b>
<b>8.0</b>	<b>Connectors</b>
<b>8.1</b>	<b>DC Output Wire List</b>
<b>8.2</b>	<b>AC Input</b>
<b>9.0</b>	<b>Environmental</b>
<b>9.1</b>	<b>Temperature</b>
<b>9.2</b>	<b>Relative Humidity</b>
<b>9.3</b>	<b>Altitude</b>
<b>9.4</b>	<b>Shock</b>
<b>9.5</b>	<b>Vibration</b>
<b>9.6</b>	<b>Power Line Transient</b>
<b>9.7</b>	<b>Acoustic Noise</b>
<b>10.0</b>	<b>Regulatory Agency Certification</b>
<b>10.1</b>	<b>RFI/EMI Standards</b>
<b>10.2</b>	<b>Safety Standards</b>
<b>11.0</b>	<b>Reliability</b>
<b>11.1</b>	<b>Mean Time Between Failures (MTBF)</b>
<b>11.2</b>	<b>Warranty</b>

## 1.0 General

This specification describes the physical, functional and electrical characteristics of a redundancy 900+450 watt, 6-output, fan-cooled switching power supply, with active PFC Function.

## 1.1 Parameter Specifications

Unless specified otherwise, all parameters must be not over the limits of temperature, load and input voltage.

## 2.0 Input Characteristics

### 2.1 Input Voltage

Input voltage range set with a FULL RANGE 90 ~ 264 VAC.

### 2.2 Input Waveform

The unit is capable of operating with a 10% distorted sinewave input as measured by a distortion analyzer. Its flattopping clipped 10% from the peak value of standard sinewave.

### 2.3 Input Frequency

47 Hz to 63 Hz

### 2.4 Input current

<b>Input Power</b>	1170W
<b>Vin: 115VAC</b>	16 A
<b>Vin: 230VAC</b>	11 A

### 2.5 In-Rush Current

#### CONDITIONS

90 ~ 264VAC, full load.  
Turn off 1 sec; turn on at  
peak of input voltage cycle.  
25°C Air Ambient cold start.

#### LIMITS

No damage shall occur or  
components over stressed,  
input fuse shall not blow.

### 2.6 Line Regulation

Full load, +/-1% 90 ~ 264 VAC input

## 2.7 Input Leakage Current

Input leakage current from line to ground will be less than 3.5 mA rms. measurement will be made at 240 VAC and 60Hz.

## 2.8 Isolation (Hi-pot)

1500VRMS, 50Hz, for one (1) minute between each input AC line and the grounding conductor.

3000VRMS, 50Hz, for one (1) Minute between the input AC lines and secondary low voltage outputs and shields.

All isolation transformers will have been tested prior to assembly into a power supply unit. Any such transformers without a grounded shield will be tested to 3750 VRMS.

## 3.0 Output Characteristics

### 3.1 DC Output Characteristics

To be met under all combinations of loading.

Output Voltage	V1 +5V	V2 3.3V	V3 +12V	V4 -5V	V5 -12V	5VSB Standby
Max. Load	60A	35A	62A	1A	1A	3A
Min. Load	3A	0A	1A	0A	0A	0A
Max. Power	350W			5W	12W	15W
	868W					
Load Reg. %	+/-5%	+5/-3%	+/-5%	+/-10%	+/-10%	+/-5%
Cross Reg. %	+/-5%	+5/-3%	+/-5%	+/-10%	+/-10%	+/-5%
Line Reg. %	+/-1%	+/-1%	+/-1%	+/-1%	+/-1%	+/-1%
Ripple %	+/-1%	+/-1%	+/-1%	+/-2%	+/-2%	+/-1%
Noise %	+/-1%	+/-1%	+/-1%	+/-2%	+/-2%	+/-1%

**Note 1:** The +12 Volt output of the power supply must be capable of 65 Amps peak for 10 seconds. A +/-5% tolerance is permissible. Output voltage is measured at the load and of the output cable.

**Note 2:** Noise bandwidth is from DC to 20 MHz.

**Note 3:** Regulation tolerance shall include temperature change, warm up drift and dynamic load.

### **3.2 Overshoot**

Any output overshoot at TURN-ON shall not exceed 5% (+5V/+12V/+3.3V outputs) and 10% (-5V/-12V outputs) of nominal voltage value.

### **3.3 Efficiency**

70% min. at full load test.

## **4.0 Time Sequence**

### **4.1 Hold-Up Time**

Unit shall continue to supply regulated DC outputs and power good signal for at least 20 milliseconds at 90 ~ 264 VAC full load after a loss of AC input voltage, which shall be represented by a short circuit at the AC input.

### **4.2 Power Good Signal**

When the power supply is turned off for a minimum of 1.0 second and turned on, the power-good signal as described below will be generated. The power supply shall provide a power-good signal to indicate proper operation of the power supply. This signal shall be a TTL compatible high level for normal operation; low level for fault conditions. Power-good shall go to a low level at least 1 ms before the +5V output voltage falls below the regulation limits described in 3.1 DC output Characteristics. The operation point used as a reference for measuring the 1ms shall be minimum line voltage and maximum load.

All waveform transitions shall be smooth and monotony, i.e. no oscillations. The power-good signal shall stay low (during POWER-ON) until all output voltages are stable within regulation limits. The power-good signal shall have a TURN-ON delay greater than 100 ms but less than 500 ms

#### **4.2.1 Fan-out**

Power-Good output circuit shall consist of an active pull down component and a passive pull up resistor. Power-Good output voltage to be met under recommended loading conditions.

#### **CONDITIONS**

IoH= -140uA Min.

IoL= 2.8mA Min.

#### **LIMITS**

VoH= 2.7V Min.

VoL= 0.4V Min.

### **4.3 +5 V & +3.3V and Power Good Outputs Rise Time**

### 4.3.1 +5 V & +3.3V Output Rise Time

The +5 Volt and +3.3 Volt output shall have a turn-on rise time of less than 100ms under all load conditions. Rise time is measured between 0.0 and 2.48/4.75 volts. The +5 V and +3.3V output shall not vary from a smooth curve by more than 0.5 VP-P during turn-on and turn-off.

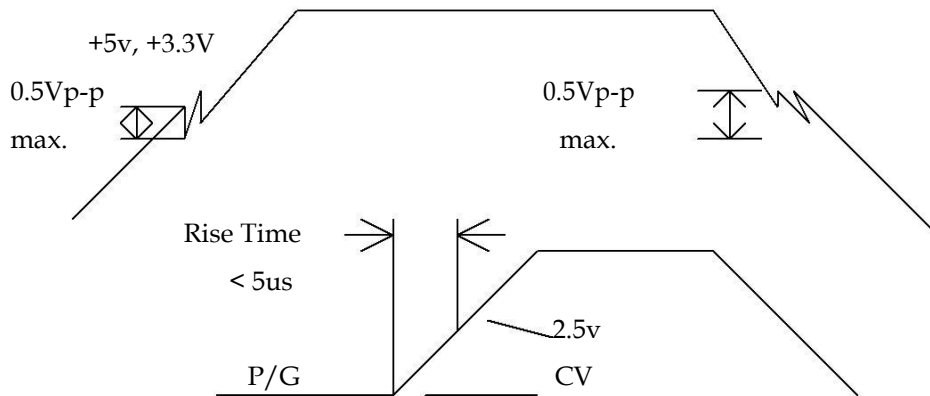

### 4.4 Start-up timing

All outputs shall be stable and in regulation in less than 2.0 second under all load and line conditions. Start-up time is measured between the AC turn-on and 4.75 volts on +5v output.

### 4.5 Dynamic Load Response Time

Transient response is measured by switching the output load from 80 to 100 to 80 percent of its full value at a frequency of 100 Hz and 50% duty cycle, step load change is 0.5A/us, The magnitude  $V_r$  is less than +/- 5% of +5V and +12V outputs, the recovery time  $T_r$  is less than 1ms.

### 5.0 Protection

#### 5.1 Over Power Protection

This power supply shut down all DC outputs when +5 Vdc and +12 Vdc outputs are overloaded to the limit. The power supply logic shall latch into the off state requiring a power on cycle to be performed by the operator. The power supply will turn-off within 20 ms of the occurrence of the overload. The -5 Vdc and -12 Vdc outputs will be internally current limited.

#### CONDITIONS

90 ~ 264 VAC input

#### LIMIT

When output power is over to 120%

## 5.2 Over Voltage Protection

The power supply shall latch off if the +5 VDC or 3.3VDC or +12 VDC maximum voltages exceeds the limits shown. The AC must be recycled to restart.

### +5 VDC

#### CONDITIONS

All operating

#### LIMITS

6.25 VDC +/- 0.65 VDC

### +3.3 VDC

#### CONDITIONS

All operating

#### LIMITS

4.10 VDC +/- 0.40 VDC

### +12 VDC

#### CONDITIONS

All operating

#### LIMITS

13.6 – 15.6 VDC

## 5.3 Short Circuit Protection

A short circuit placed on any output shall cause no damage to this unit.

## 5.4 No Load Operation

When primary power is applied, with no load on any output voltage, no damage or hazardous conditions shall occur. In such a case, the power supply shall power up and stabilize. However, minimum load required 3A for +5V and 1A for +12V.

## 5.5 5VSB (Standby)

The 5VSB output is always on (+5V Standby) when AC power is applied and power switch is turned on. The 5VSB line is capable of delivering at a maximum of 5A for PC board circuit to operate.

## 5.6 PS-ON (Remote ON/OFF)

PS-ON is an active low signal that turns on the entire main power rail including 3.3V, 5V, -5V, 12V & -12V power rails. When this signal is held by the PC board or left open circuited, outputs of the power rails should not deliver current and should be held at a zero potential with respect to ground. Power should only be delivered to the rails if PS-ON signal is held at ground potential. This signal should be held at +5VDC by a pull-up resistor internal to the power supply.



Power On	P1-PIN #14 PS-ON	Power Switch	P1-PIN #14 PS-ON
ON	L	ON	IN
OFF	H	ON	IN
OFF	X	ON	OUT
OFF	X	OFF	X

## 5.7 3.3V Sense

A remote 3.3V sense line can be added to the P1 connector Pin2 to allow for accurate control of the 3.3VDC line directly at motherboard loads. Due to potential voltage drops across the connector and traces leading to the motherboard components, it may be advantageous to implement a 3.3V sense line that remotely monitors the 3.3VDC power level at the load on the motherboard.

## 6.0 System Interface Signal

### 6.1 Power System Fault Signal

The Hot-Swap Redundant Power Supply shall give fault signal (an open collector output) that will indicate the status of the power supply operation. If one of the power supply unit shut down, the power fault signal could be generated. This signal shall be high level for normal operation; Low level for fault conditions.

### 6.2 Alarm Beeping Sound

The alarm system monitors the power supply failure and provides alarm to indicate the status of the power system. By checking the LED on the power supply, end users will be able to locate the defective power unit. The alarm system will give a beeping sound to indicate the power supply failure until that particular power unit is replaced. Beeping sound could be suspended before the failure power supply unit replaced by pressing the Alarm Switch.

## 7.0 Physical Characteristics

### 7.1 Size

150 \* 86 \* 230mm

### 7.2 Mounting Requirements

See Figure 6

### 7.3 Weight

4.2 Kg

## 7.4 Cooling

**Fans:** SUNON (KD1204PQB1-A), or equivalent or better. Airflow from the power supply should be in exhaust direction and shall be rated at 24 cfm minimum.

## 8.0 Connections

### 8.1 DC Output Wire List

+For ATX Mother Board

<u>Connector</u>	<u>Output</u>	<u>Wire Color</u>	<u>Wire Size</u>
<b>ATX 24 Pin</b>			
P1-1	+3.3V	BRN	16 AWG
P1-2	+3.3V	BRN	16 AWG
P1-3	GND	BLK	18 AWG
P1-4	+5V	RED	18 AWG
P1-5	GND	BLK	18 AWG
P1-6	+5V	RED	18 AWG
P1-7	GND	BLK	18 AWG
P1-8	PW-OK	ORG	18 AWG
P1-9	5VSB	PURPLE	18 AWG
P1-10	+12V	YEL	18 AWG
P1-11	+12V	YEL	18 AWG
P1-12	+3.3V	BRN	16 AWG
P1-13	+3.3V	BRN	16 AWG
P1-14	-12V	BLUE	18 AWG
P1-15	GND	BLK	18 AWG
P1-16	PS-ON	GREEN	18 AWG
P1-17	GND	BLK	18 AWG
P1-18	GND	BLK	18 AWG
P1-19	GND	BLK	18 AWG
P1-20	NG	NG	NG
P1-21	+5V	RED	18 AWG
P1-22	+5V	RED	18 AWG
P1-23	+5V	RED	18 AWG
P1-24	GND	BLK	18 AWG
<b>8PIN 12V FOR P4</b>			
P1-1	GND	BLK	18 AWG
P1-2	GND	BLK	18 AWG
P1-3	GND	BLK	18 AWG

P1-4	GND	BLK	18 AWG
P1-5	+12V	YEL	18 AWG
P1-6	+12V	YEL	18 AWG
P1-7	+12V	YEL	18 AWG
P1-8	+12V	YEL	18 AWG
<b>P11, P12</b>			
P11-1	+5V	RED	22 AWG
P11-2	COM	BLK	22 AWG
P11-3	COM	BLK	22 AWG
P11-4	+12V	YEL	22 AWG
<b>P13, P14</b>			
Pn-1	+12V	YEL	18 AWG
Pn-2	COM	BLK	18 AWG
Pn-3	COM	BLK	18 AWG
Pn-4	+5V	RED	18 AWG
<b>P15, P16</b>			
Pn-1	+12V	YEL	18 AWG
Pn-2	COM	BLK	18 AWG
Pn-3	COM	BLK	18 AWG
Pn-4	+5V	RED	18 AWG
<b>P17, P18</b>			
Pn-1	+12V	YEL	18 AWG
Pn-2	COM	BLK	18 AWG
Pn-3	COM	BLK	18 AWG
Pn-4	+5V	RED	18 AWG

## 8.2 AC Input

IEC 320 power inlet with EMI filter.

(Delta 6A, Part Number: 06GEEG3E)

## 9.0 Environmental

### 9.1 Temperature

#### 9.1.1 Operating

50 to 122 °F (0 to 50 °C). Derate Linearly to 50% at 70 °C

#### 9.1.2 Non-Operating

-4.0 to 140 °F (-20 to 60°C)

## **9.2 Relative Humidity**

### **9.2.1 Operating**

20 to 90 % non-condensing at 104°F (40 °C).

### **9.2.2 Non-Operating**

5 to 95 % non-condensing at 122°F (50°C).

## **9.3 Altitude**

### **9.3.1 Operating**

Sea level to 10,000 feet.

### **9.3.2 Non-Operating**

Sea level to 40,000 feet.

## **9.4 Shock**

### **9.4.1 Operating**

The power supply shall exhibit no signs of damage or degradation of performance when subjected to a shock of 5g's for 11 ms, with a 1/2 sine wave for each of the perpendicular axes X, Y and Z.

### **9.4.2 Non-Operating**

The power supply shall exhibit no signs of damage or degradation of performance when subjected to a shock of 30g's for 11 ms, with a 1/2 sine wave for each of the perpendicular axes X, Y and Z.

## **9.5 Vibration**

### **9.5.1 Operating**

The power supply shall be subjected to a vibration test consisting of a 10 to 500 Hz sweep at a constant acceleration of 0.5g for duration of one (1) hour for each of the perpendicular axes X, Y and Z.

The output voltages shall remain within specification.

### **9.5.2 Non-Operating**

The power supply shall be subjected to a vibration test consisting of a 10 to 300 Hz sweep at a constant acceleration of 2.0g for duration of one (1) hour for each of the perpendicular axes X, Y and Z.

The power supply shall not incur physical damage or degradation of any

characteristics below the performance specifications.

## 9.6 Power Line Transient

### 9.6.1 Drop Out

With a full cycle input voltage drop-out at 50Hz, the unit shall operating within the prescribed voltages with a drop-out cycle repetition rate of 500ms.

#### CONDITIONS

Full load, Nom. Input AC Voltage

#### LIMITS

Meet all requirements

### 9.6.2 Transient Voltage Spikes

The unit shall meet the following standards, The IEEE Standard 587-1980 for surge withstand capability under categories A and B. The crest value of the first half peak of the injected Ringwave (0.5/10us) and Biwave (1.2/50us) will be 3K volts open circuit and 3KA (8us×20us) short circuit.

IEC 801-2 (ESD) to a level of 8KV contact, and 15K air discharge without causing the device(s) to fail the test.

IEC 801-4 (EFT) on the power lines and all I/O cables to a level of 2.5KV without causing the Device(s) to fail the test.

IEC 801-5 Surge immunity measurement on the input power source of 2.5KV.

All output shall be stable and in regulation.

## 9.7 Acoustic Noise

The power supply shall be tested in accordance with the ANSIS12.10-1985 standard specifications. The "A" weighted overall sound pressure level as well as individual octave band levels from 63 Hz to 16,000 Hz is measured with the noise meter placed 1 meter from the nearest vertical surface of center of fan installed in power supply.

#### CONDITIONS

115 VAC Input, full load of +5V  
0.5A of +12V.

#### LIMITS

Acoustic noise is 40 db maximum

Octave Band Center Frequency (Hz)								A-Weighted
125	250	500	1k	2k	4k	8k	16k	Max. Sum
20	36	42	42	42	36	30	20	40dBA

## **10.0 Regulatory Agency Certification**

### **10.1 RFI/EMI Standards**

The power supply, when installed in system, shall MEETS with the following radiated and conducted emissions standards:

- a) FCC part 15, Subpart A, Class A computing devices.
- b) CISPR22 (EN55022) Class A.
- c) VCCI Class 2.

These limits shall be met with a margin of at less 6dB at all applicable frequencies. The unit shall comply with the above limits when tested under all normal working conditions and with all interface cables connected.

### **10.2 Safety Standards**

The power supply shall be MEETS with the following safety standards,

- a) UL 1950 (Information Processing/Business equipment).
- b) CSA C22.2, NO. 234-M90 level 6 (Safety of component, power supplies) or CSA C22.2, NO. 950-M89.
- c) TUV Certification to IEC 950 1st edition with Amendment #1, #2, and EN60950
- d) CB Certificate & Test report deviation for the Nordic countries.
- e) CE Certificate & Test report.

## **11.0 Reliability**

### **11.1 Mean Time Between failures (MTBF)**

Using MIL217E the calculated MTBF = 100,000 hours at 25°C

### **11.2 Warranty**

Two (2) years manufacture's warranty

Date code indicating week and year of manufacture.

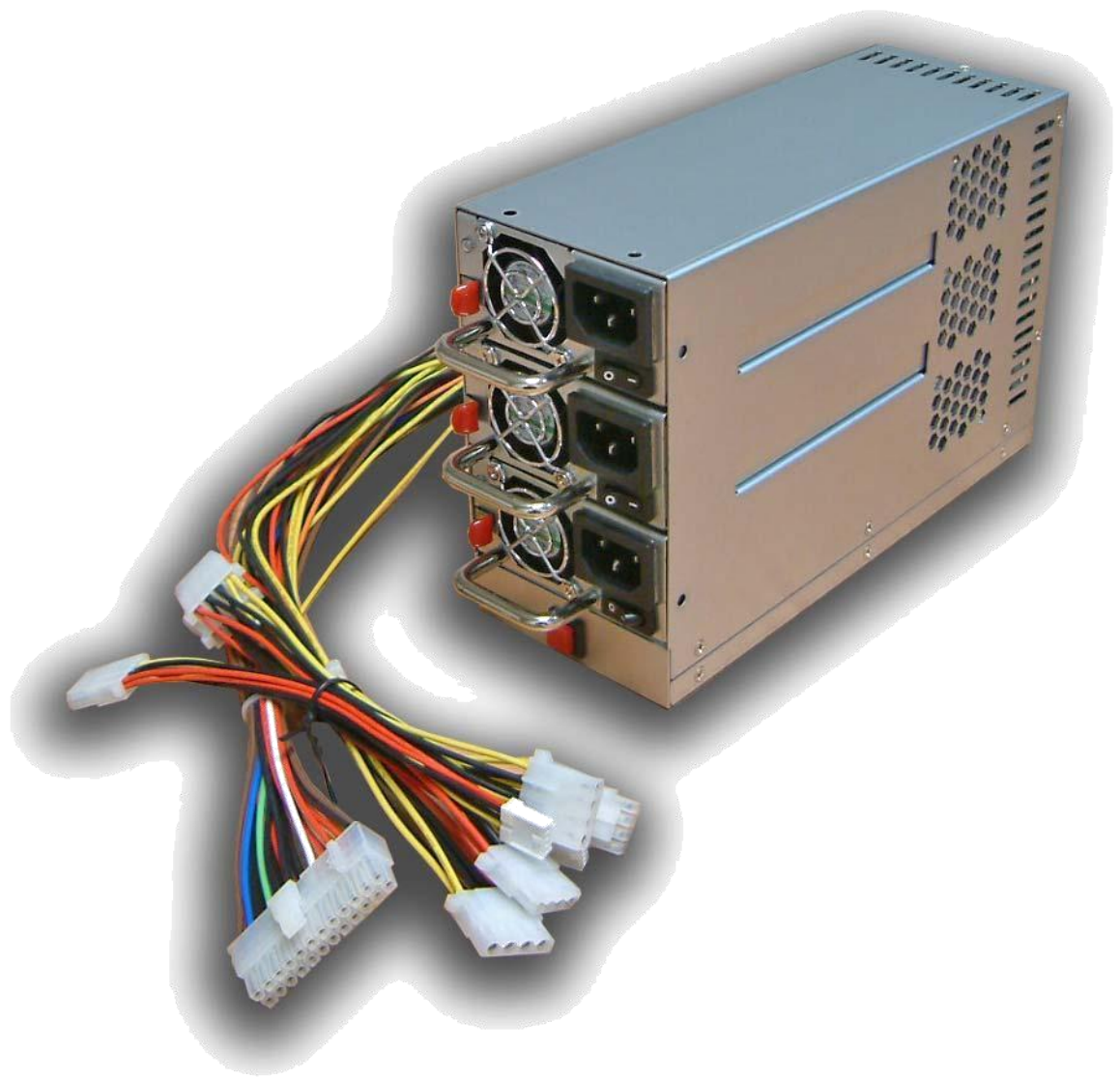

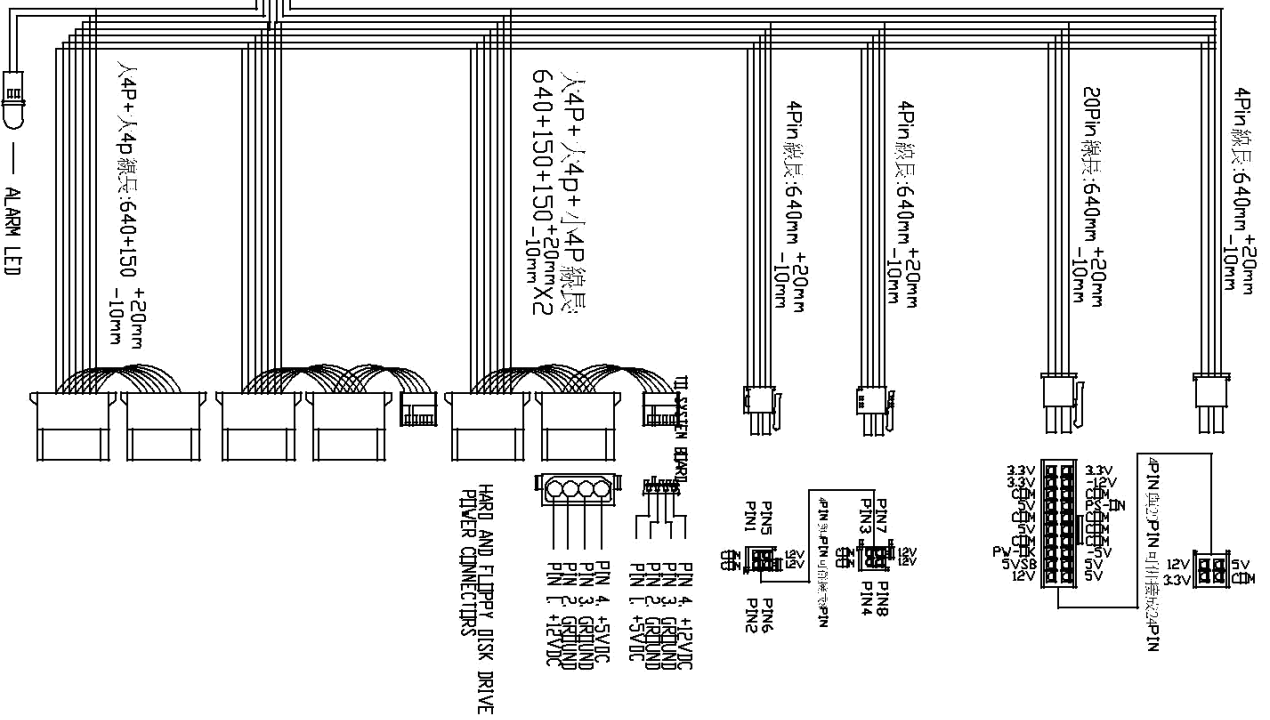
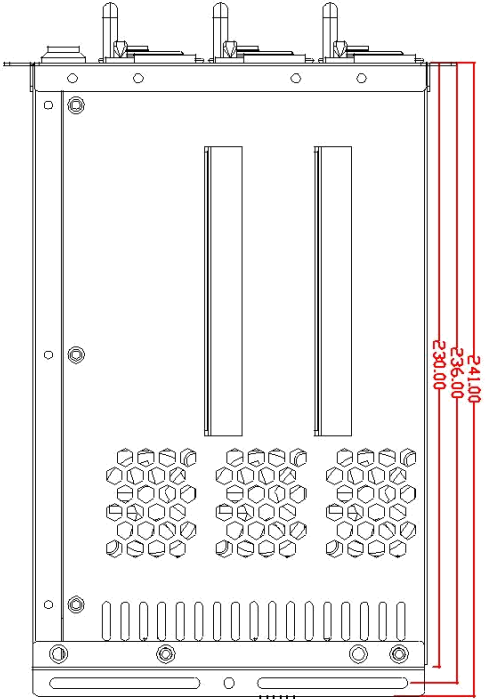
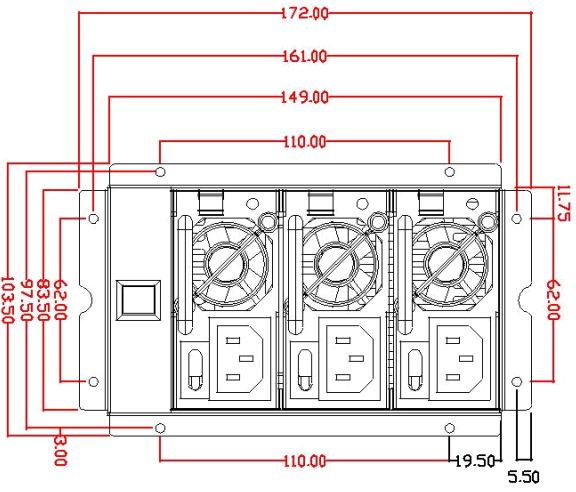
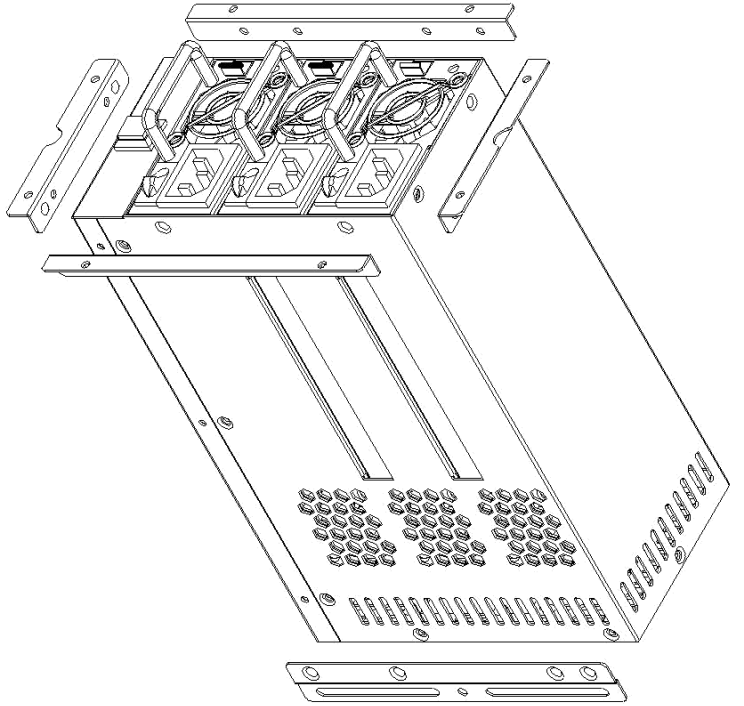
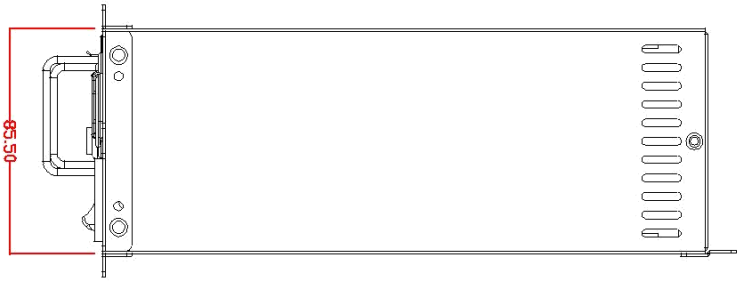

BEST POWER SOLUTION INC.		SCALE:		TITLE: 4U REMOUNT		REV: 1/1	
FILE NO:	BP-S-700RP3 / 800PR3 / 900RP3	APP:	CHK:	DRN:	REV:	DRY:	97213
UNIT:	mm	SHEET:	1/1	REV:	1/1	DRY:	97213
MODEL:		DATE:		BY:		CHK:	
				DATE: 02/20/2013			
				TIME: 10:41:47			
				USER: 20130220			
				IP: 192.168.1.100			
				PRT: 255.255.255.255			
				PRN: 255.255.255.255			
				PRN: 255.255.255.255			
				PRN: 255.255.255.255			
				PRN: 255.255.255.255			