

SPECIFICATION

SWITCHING POWER SUPPLY

BPS-300SPP 6-OUTPUT

WITH ACTIVE PFC FUNCTION

SINGLE POWER 300W

BEST POWER SOLUTIONS, INC.

9F, NO.196-7, SEC.3, TA-TUNG RD SHI CHIH,
TAIPEI, TAIWAN, R.O.C.

Tel: 886-2-8647-1188

Fax: 886-2-8647-3322

1.0	General
1.1	Parameter Specifications
2.0	Input Characteristics
2.1	Input Voltage
2.2	Input Waveform
2.3	Input Frequency
2.4	Input Current
2.5	In-Rush Current
2.6	Line Regulation
2.7	Input Leakage Current
2.8	Isolation (Hi-Pot)
3.0	Output Characteristics
3.1	DC Output Characteristics
3.2	Overshoot
3.3	Efficiency
4.0	Time Sequence
4.1	Hold-Up Time
4.2	Power Good Signal
4.3	+5 Volt & +3.3V Power Good Output Rise Time
4.4	Start-Up Time
4.5	Dynamic Load Response Time
5.0	Protection
5.1	Over Power Protection
5.2	Over Voltage Protection
5.3	Short Circuit Protection
5.4	No Load Operation
5.5	5VSB (Standby)
5.6	PS-ON (Remote ON/OFF)
5.7	3.3V Sense
6.0	Physical Characteristics
6.1	Size
6.2	Mounting Requirements

6.3	Weight
6.4	Cooling
7.0	Connectors
7.1	DC Output Wire List
7.2	AC Input
8.0	Environmental
8.1	Temperature
8.2	Relative Humidity
8.3	Altitude
8.4	Shock
8.5	Vibration
8.6	Power Line Transient
8.7	Acoustic Noise
9.0	Regulatory Agency Certification
9.1	RFI/EMI Standards
9.2	Safety Standards
10.0	Reliability
10.1	Mean Time Between Failures (MTBF)
10.2	Warranty

1.0 General

This specification describes the physical, functional and electrical characteristics of a single power 300 watts, 6-output, fan-cooled switching power supply with Active PFC function.

1.1 Parameter Specifications

Unless specified otherwise, all parameters must be not over the limits of temperature, load and input voltage.

2.0 Input Characteristics

2.1 Input Voltage

Input voltage range set with FULL RANGE (115~240VAC).

2.2 Input Waveform

The unit is capable of operating with a 10% distorted sinewave input as measured by a distortion analyzer. Its flattopping clipped 10% from the peak value of standard sinewave.

2.3 Input Frequency

47 Hz to 63 Hz

2.4 Input current

Input Power	430W
Vin: 110VAC	6 A
Vin: 240VAC	3.5 A

2.5 In-Rush Current

CONDITIONS

132/264VAC, Full load.

Turn off 1 sec; turn on at peak of input voltage cycle.

25°C Air Ambient cold start.

LIMITS

No damage shall occur or components over stressed, input fuse shall not blow.

2.6 Line Regulation

CONDITIONS

Full load,
115 ~ 240VAC input

LIMITS

+/-1%

2.7 Input Leakage Current

Input leakage current from line to ground will be less than 3.5 mA rms. Measurement will be made at 240 VAC and 60Hz.

2.8 Isolation (Hi-pot)

1500VRMS, 50Hz, for one (1) minute between each input AC line and the grounding conductor.

3000VRMS, 50Hz, for one (1) Minute between the input AC lines and secondary low voltage outputs and shields.

All isolation transformers will have been tested prior to assembly into a power supply unit. Any such transformers without a grounded shield will be tested to 3750 VRMS.

3.0 Output Characteristics

3.1 DC Output Characteristics

To be met under all combinations of loading.

Output Voltage	V1 +5	V2 3.3V	V3 +12V	V4 -5V	V5 -12V	5VSB Standby
Max. Load	30A	20A	12A	0.5A	1A	1.5A
Min. Load	3A	0A	1A	0A	0A	0A
Max. Power	150W			2.5W	12W	7.5W
	278W					
Load Reg. %	+/-5%	+5/-3%	+/-5%	+/-10%	+/-10%	+/-5%
Cross Reg. %	+/-5%	+5/-3%	+/-5%	+/-10%	+/-10%	+/-5%
Line Reg. %	+/-1%	+/-1%	+/-1%	+/-1%	+/-1%	+/-1%
Ripple %	+/-1%	+/-1%	+/-1%	+/-2%	+/-2%	+/-1%
Noise %	+/-1%	+/-1%	+/-1%	+/-2%	+/-2%	+/-1%

Note 1: The +12 Volt output of the power supply must be capable of 16 Amps peak for 10 seconds. A +/-5% tolerance is permissible. Output voltage is measured at the load and of the output cable.

Note 2: Noise bandwidth is from DC to 20 MHz.

Note 3: Regulation tolerance shall include temperature change, warm up

drift and dynamic load.

3.2 Overshoot

Any output overshoot at TURN-ON shall not exceed 5% (+5V/+12V/+3.3V outputs) and 10% (-5V/-12V outputs) of nominal voltage value.

3.3 Efficiency

70% min. at full load test.

4.0 Time Sequence

4.1 Hold-Up Time

Unit shall continue to supply regulated DC outputs and power good signal for at least 20 milliseconds at 100~240VAC full load after a loss of AC input voltage which shall be represented by a short circuit at the AC input.

4.2 Power Good Signal

When the power supply is turned off for a minimum of 1.0 second and turned on, the power-good signal as described below will be generated. The power supply shall provide a power-good signal to indicate proper operation of the power supply. This signal shall be a TTL compatible high level for normal operation; low level for fault conditions. Power-good shall go to a low level at least 1 ms before the +5V output voltage falls below the regulation limits described in 3.1 DC output Characteristics. The operation point used as a reference for measuring the 1ms shall be minimum line voltage and maximum load. All waveform transitions shall be smooth and monotony, i.e. no oscillations. The power-good signal shall stay low (during POWER-ON) until all output voltages are stable within regulation limits. The power-good signal shall have a TURN-ON delay greater than 100 ms but less than 500 ms.

4.2.1 Fan-out

Power-Good output circuit shall consist of an active pull down component and a passive pull up resistor.

Power-Good output voltage to be met under recommended loading conditions.

CONDITIONS

IoH= -140uA Min.

IoL= 2.8mA Min.

LIMITS

VoH= 2.7V Min.

VoL= 0.4V Min.

4.3 +5 V & +3.3V and Power Good Outputs Rise Time

4.3.1 +5 V & +3.3V Output Rise Time

The +5 Volt and +3.3 Volt output shall have a turn-on rise time of less than 100ms under all load conditions. Rise time is measured between 0.0 and 2.48/4.75 volts. The +5 V and +3.3V output shall not vary from a smooth curve by more than 0.5 VP-P during turn-on and turn-off.

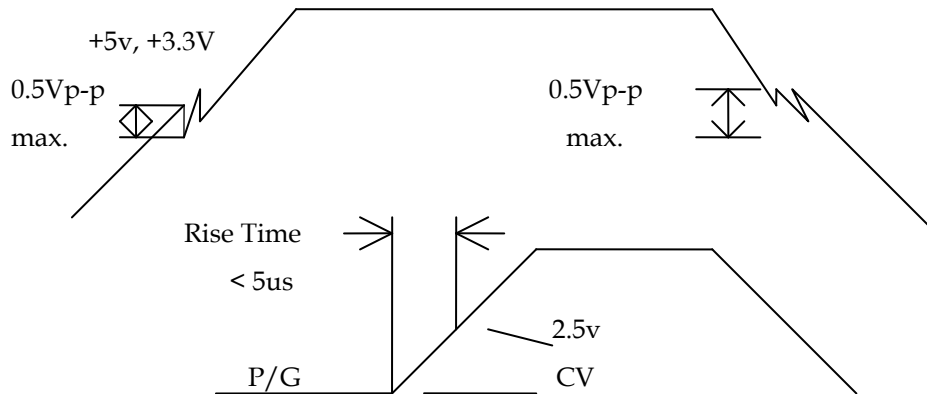

4.4 Start-up timing

All outputs shall be stable and in regulation in less than 2.0 second under all load and line conditions. Start-up time is measured between the AC turn-on and 4.7 volts on +5v output.

4.5 Dynamic Load Response Time

Transient response is measured by switching the output load from 80 to 100 to 80 percent of its full value at a frequency of 100 Hz and 50% duty cycle, step load change is 0.5A/ μs , The magnitude V_r is less than $\pm 5\%$ of +5V and +12V outputs, the recovery time T_r is less than 1ms. See Figure 2.

5.0 Protection

5.1 Over Power Protection

This power supply shut down all DC outputs when +5 Vdc and +12 Vdc outputs are overloaded to the limit. The power supply logic shall latch into the off state requiring a power on cycle to be performed by the operator. The power supply will turn-off within 20 ms of the occurrence of the overload. The -5 Vdc and -12 Vdc outputs will be internally current limited.

CONDITIONS

90/180 VAC input

LIMIT

When output power is over to 120%

5.2 Over Voltage Protection

The power supply shall latch off if the +5 VDC or 3.3VDC or +12 VDC maximum voltages exceeds the limits shown. The AC must be recycled to restart.

+5 VDC

CONDITIONS

All operating

LIMITS

6.25 VDC +/- 0.65 VDC

+3.3 VDC

CONDITIONS

All operating

LIMITS

4.10 VDC +/- 0.40 VDC

+12 VDC

CONDITIONS

All operating

LIMITS

13.6 – 15.6 VDC

5.3 Short Circuit Protection

A short circuit placed on any output shall cause no damage to this unit.

5.4 No Load Operation

When primary power is applied, with no load on any output voltage, no damage or hazardous conditions shall occur. In such a case, the power supply shall power up and stabilize. However, minimum load required 3A for +5V and 1A for +12V.

5.5 5VSB (Standby)

The 5VSB output is always on (+5V Standby) when AC power is applied and power switch is turned on. The 5VSB line be capable of delivering at a maximum of 5A for PC board circuit to operate.

5.6 PS-ON (Remote ON/OFF)

PS-ON is an active low signal that turns on the entire main power rail including 3V, 5V, -5V, 12V & -12V power rails. When this signal is held by the PC board or left open circuited, outputs of the power rails should not deliver current and should be held at a zero potential with respect to ground. Power should only be delivered to the rails if PS-ON signal is held at ground potential. This signal should be held at +5VDC by a pull-up

resistor internal to the power supply.

Power On	P1-PIN #14 PS-ON	Power Switch	P1-PIN #14 PS-ON
ON	L	ON	IN
OFF	H	ON	IN
OFF	X	ON	OUT
OFF	X	OFF	X

5.7 3.3V Sense

A remote 3.3V sense line can be added to the P1 connector Pin2 to allow for accurate control of the 3.3VDC line directly at motherboard loads. Due to potential voltage drops across the connector and traces leading to the motherboard components, it may be advantageous to implement a 3.3V sense line that remotely monitors the 3.3VDC power level at the load on the motherboard.

6.0 Physical Characteristics

6.1 Size

150*86*140mm

6.2 Mounting Requirements

See Figure 6

6.3 Weight

1.4 Kg

6.4 Cooling

Fans: SUNON (KD1206 PTB1), equivalent or better. Air flow from the power supply should be in exhaust direction and shall be rated at 20.8 cfm minimum.

7.0 Connections

7.1 DC Output Wire List

+ For ATX Mother Board

<u>Connector</u>	<u>Output</u>	<u>Wire Color</u>	<u>Wire Size</u>
<u>ATX 20pin</u>			
P1-1	+3.3V	BRN	16 AWG
P1-2	+3.3V	BRN	16 AWG

P1-3	GND	BLK	18 AWG
P1-4	+5V	RED	18 AWG
P1-5	GND	BLK	18 AWG
P1-6	+5V	RED	18 AWG
P1-7	GND	BLK	18 AWG
P1-8	PW-OK	ORG	18 AWG
P1-9	5VSB	BRN	18 AWG
P1-10	+12V	YEL	18 AWG
P1-11	+3.3V	BRN	16 AWG
P1-12	-12V	BLUE	18 AWG
P1-13	GND	BLK	18 AWG
P1-14	PS-ON	GRN	18 AWG
P1-15	GND	BLK	18 AWG
P1-16	GND	BLK	18 AWG
P1-17	GND	BLK	18 AWG
P1-18	-5V	WHT	18 AWG
P1-19	+5V	RED	18 AWG
P1-20	+5V	RED	18 AWG
4 PIN for P4			
Pn-1	COM	BLK	18 AWG
Pn-2	COM	BLK	18 AWG
Pn-3	+12V	YEL	18 AWG
Pn-4	+12V	YEL	18 AWG
P11 、 P12			
Pn-1	+12V	YEL	22 AWG
Pn-2	COM	BLK	22 AWG
Pn-3	COM	BLK	22 AWG
Pn-4	+5V	RED	22 AWG
P13 、 P14			
Pn-1	+12V	YEL	18 AWG
Pn-2	COM	BLK	18 AWG
Pn-3	COM	BLK	18 AWG
Pn-4	+5V	RED	18 AWG
P15 、 P16			
Pn-1	+12V	YEL	18 AWG
Pn-2	COM	BLK	18 AWG
Pn-3	COM	BLK	18 AWG
Pn-4	+5V	RED	18 AWG
P17 、 P18			
Pn-1	+12V	YEL	18 AWG
Pn-2	COM	BLK	18 AWG

Pn-3	COM	BLK	18 AWG
Pn-4	+5V	RED	18 AWG

7.2 AC Input

IEC 320 power inlet with EMI filter.

8.0 Environmental

8.1 Temperature

8.1.1 Operating

50 to 122 °F (0 to 50 °C). Derate Linearly to 50% at 70 °C

8.1.2 Non-Operating

-4.0 to 140 °F (-20 to 60°C)

8.2 Relative Humidity

8.2.1 Operating

20 to 90 % non-condensing at 104°F (40 °C).

8.2.2 Non-Operating

5 to 95 % non-condensing at 122°F (50°C).

8.3 Altitude

8.3.1 Operating

Sea level to 10,000 feet.

8.3.2 Non-Operating

Sea level to 40,000 feet.

8.4 Shock

8.4.1 Operating

The power supply shall exhibit no signs of damage or degradation of performance when subjected to a shock of 5g's for 11 ms, with a 1/2 sine wave for each of the perpendicular axes X, Y and Z.

8.4.2 Non-Operating

The power supply shall exhibit no signs of damage or degradation of performance when subjected to a shock of 30g's for 11 ms, with a 1/2 sine wave for each of the perpendicular axes X, Y and Z.

8.5 Vibration

8.5.1 Operating

The power supply shall be subjected to a vibration test consisting of a 10 to 500 Hz sweep at a constant acceleration of 0.5g for a duration of one (1) hour for each of the perpendicular axes X, Y and Z.

The output voltages shall remain within specification.

8.5.2 Non-Operating

The power supply shall be subjected to a vibration test consisting of a 10 to 300 Hz sweep at a constant acceleration of 2.0g for a duration of one (1) hour for each of the perpendicular axes X, Y and Z. The power supply shall not incur physical damage or degradation of any characteristics below the performance specifications.

8.6 Power Line Transient

8.6.1 Drop Out

With a full cycle input voltage drop-out at 50Hz, the unit shall operating within the prescribed voltages with a drop-out cycle repetition rate of 500ms.

CONDITIONS

Full load, Nom. Input AC Voltage

LIMITS

Meet all requirements

8.6.2 Transient Voltage Spikes

The unit shall meet the following standards, The IEEE Standard 587-1980 for surge withstand capability under categories A and B. The crest value of the first half peak of the injected Ring wave (0.5/10us) and Bi-wave (1.2/50us) will be 3K volts open circuit and 3KA (8us×20us) short circuit.

IEC 801-2 (ESD) to a level of 8KV contact, and 15K air discharge without causing the device(s) to fail the test.

IEC 801-4 (EFT) on the power lines and all I/O cables to a level of 2.5KV without causing the Device(s) to fail the test.

IEC 801-5 Surge immunity measurement on the input power source of 2.5KV. All output shall be stable and in regulation.

8.7 Acoustic Noise

The power supply shall be tested in accordance with the ANSIS12.10-1985 standard specifications. The "A" weighted overall sound pressure level as well as individual octave band levels from 63 Hz to 16,000 Hz is measured with the noise meter placed 1 meter from the nearest vertical surface of center of fan installed in power supply.

CONDITIONS

115 VAC Input, full load of +5V
0.5A of +12V.

LIMITS

Acoustic noise is 40 db maximum

Octave Band Center Frequency (Hz)								A-Weighted
125	250	500	1k	2k	4k	8k	16k	Max. Sum
20	36	42	42	42	36	30	20	40dBA

9.0 Regulatory Agency Certification

9.1 RFI/EMI Standards

The power supply, when installed in system, shall **MEETS** with the following radiated and conducted emissions standards:

- FCC part 15, Subpart A, Class A computing devices.
- CISPR22 (EN55022) Class A.
- VCCI Class 2.

These limits shall be met with a margin of at less 6dB at all applicable frequencies. The unit shall comply with the above limits when tested under all normal working conditions and with all interface cables connected.

9.2 Safety Standards

The power supply shall be **MEETS** with the following safety standards,

- UL 1950 (Information Processing/Business equipment).
- CSA C22.2, NO. 234-M90 level 6 (Safety of component, power supplies) or CSA C22.2, NO. 950-M89.
- TUV Certification to IEC 950 1st edition with Amendment #1, #2, and EN60950
- CB Certificate & Test report deviation for the Nordic countries.
- CE Certificate & Test report.

10.0 Reliability

10.1 Mean Time Between failures (MTBF)

Using MIL217E the calculated MTBF = 100,000 hours at 25°C

10.2 Warranty

Two (2) years manufacture's warranty. Date code indicating week and year of manufacture.

Underwriters Laboratories Inc.®

Model No.	Rated Input		SC	Output			OC	SP	EP	FC	GC
	V	Hz		Max V	Max A	Max VA					
BPS-370RDX, -320RDX, BPS-300RDX	115/230	60/50		5.4 13.4 3.4 5.1 12.7 5.4	135 73 80 1.7 1.9 5.5	460 720 106 5.1 18 23	3	1950	20B	2,6	0
BPS-400SP ORION-400SP BPS-400S2 BPS-400RM, BPS-400S, ORION-400S2, EC400S-V BPS-300RPX, BPS-300SP2, BPS-300SFP, BPS-350SFP	115/230	60/50	0	6.33 13.7 5.26 -5.76 -14.58 5.3	64.0 52.0 2.79 12 8.9 2.5	276 547 12.45 28 82 11.3	3	1950	20B	0	1
BPS-450R3, ORION-2303, ERM-450R3,	115/230	60/50	0	+5.4 +3.4 +13.2 -5.3 -13.2 +6.6Vsb	140 130 70 6.5 3.5 9.3	525 216 627 16 35 34	3	1950	20B	0	1
BPS-250DS, BPS-300DS, BPS-300DSP	-48	dc	0	5.28 3.44 12.35 -4.8 -11.82 5.22	34 36.1 29.4 1.2 0.6 3.3	139.6 93.5 291.6 3.58 4.45 15.5	3	1950	20B	2,3	0

* - Rated value.
Marking: Company name and model designation.

See General Information Preceding These Recognitions

For use only in equipment where the acceptability of the combination is determined by Underwriters Laboratories Inc.



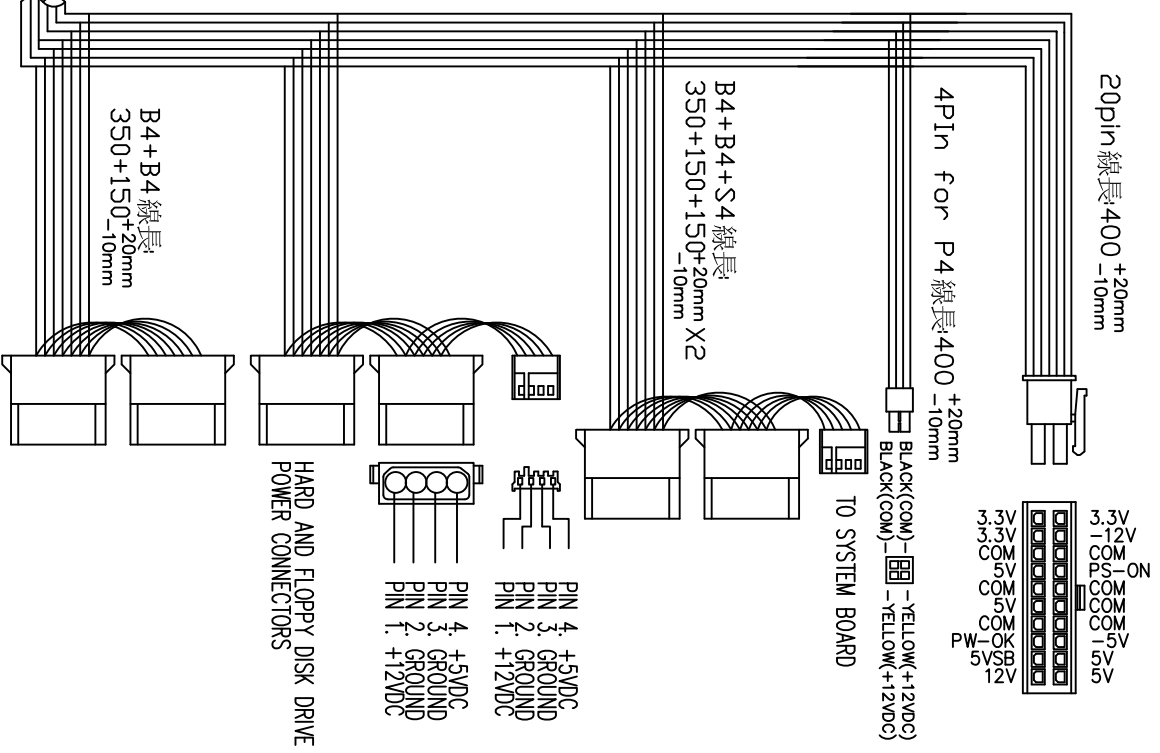
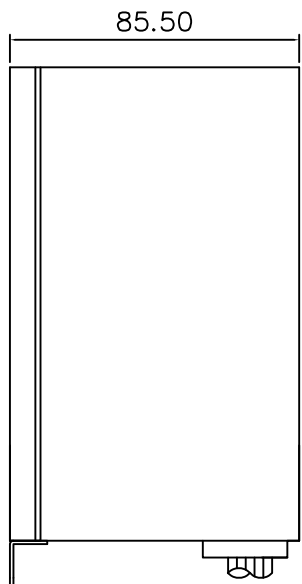
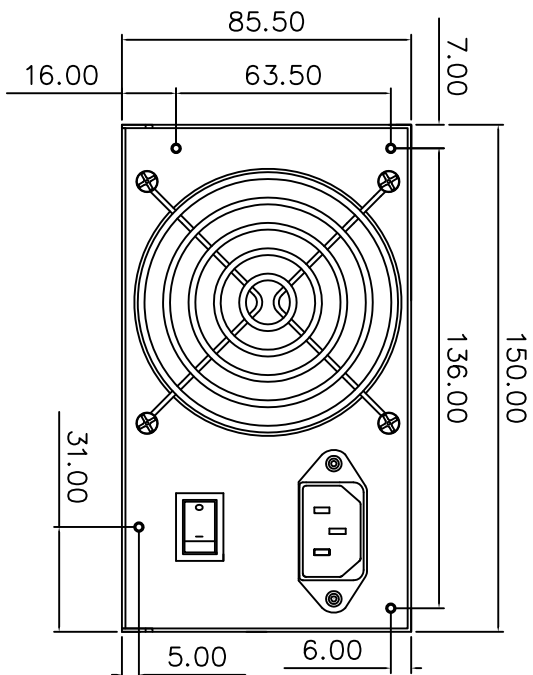
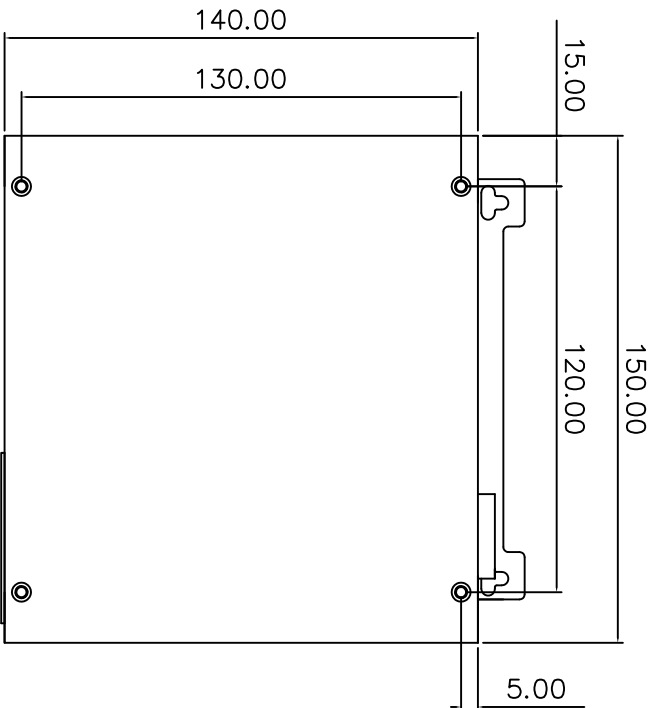

※以上線長皆為外露線長

BPS Best Power Solution, Inc		REV
Size C	Document Number BPS-300SPP	3
Date : 1999.7.5	Sheet 1 of 1	1